

Progress of the Intense Positron Beam Project EPOS

**R. Krause-Rehberg¹, G. Brauer², M. Jungmann^{1,2}, A. Krille^{1,2}
A. Rogov² and K. Noack²**

¹Martin-Luther-University Halle-Wittenberg

²Research Center Dresden-Rossendorf

- System Setup
- Electron-Positron Converter
- Positron Extraction
- Chopper / Buncher System
- Radiation Shielding



The EPOS (ELBE Positron Source) project at Research Center Dresden-Rossendorf

- Radiation source ELBE = **E**lectron **L**inac with high **B**rilliance and low **E**mittance
- Primary electron beam (40 MeV \times 1 mA = 40 kW)
- Time structure: infinite sequence of very short electron bunches (cw-mode)
- Spot size: 5mm diameter

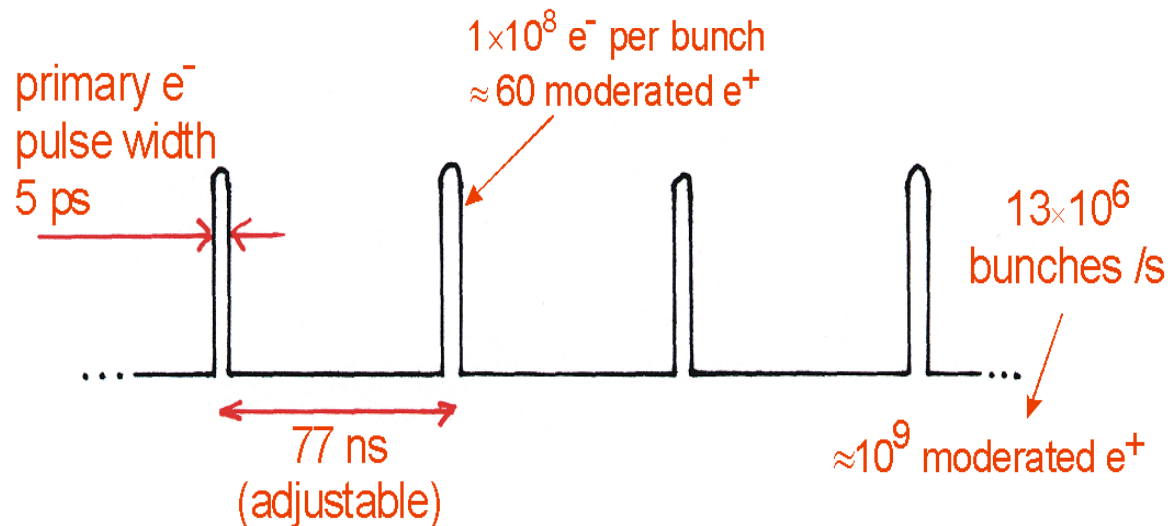

electron bunch structure

The EPOS (ELBE Positron Source) project at Research Center Dresden-Rossendorf

- Radiation source ELBE = **E**lectron **L**inac with high **B**rilliance and low **E**mittance
- Primary electron beam (40 MeV \times 1 mA = 40 kW)
- Time structure: infinite sequence of very short electron bunches (cw-mode)
- Spot size: 5mm diameter

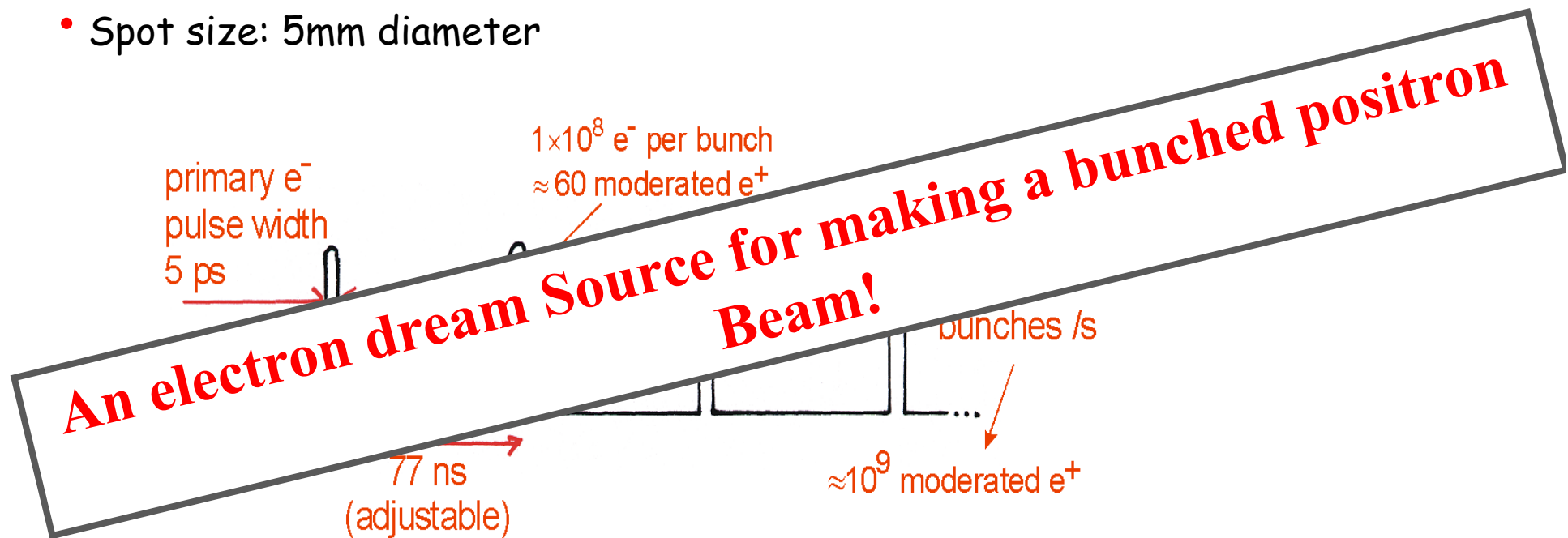

electron bunch structure

Ground plan of the ELBE hall

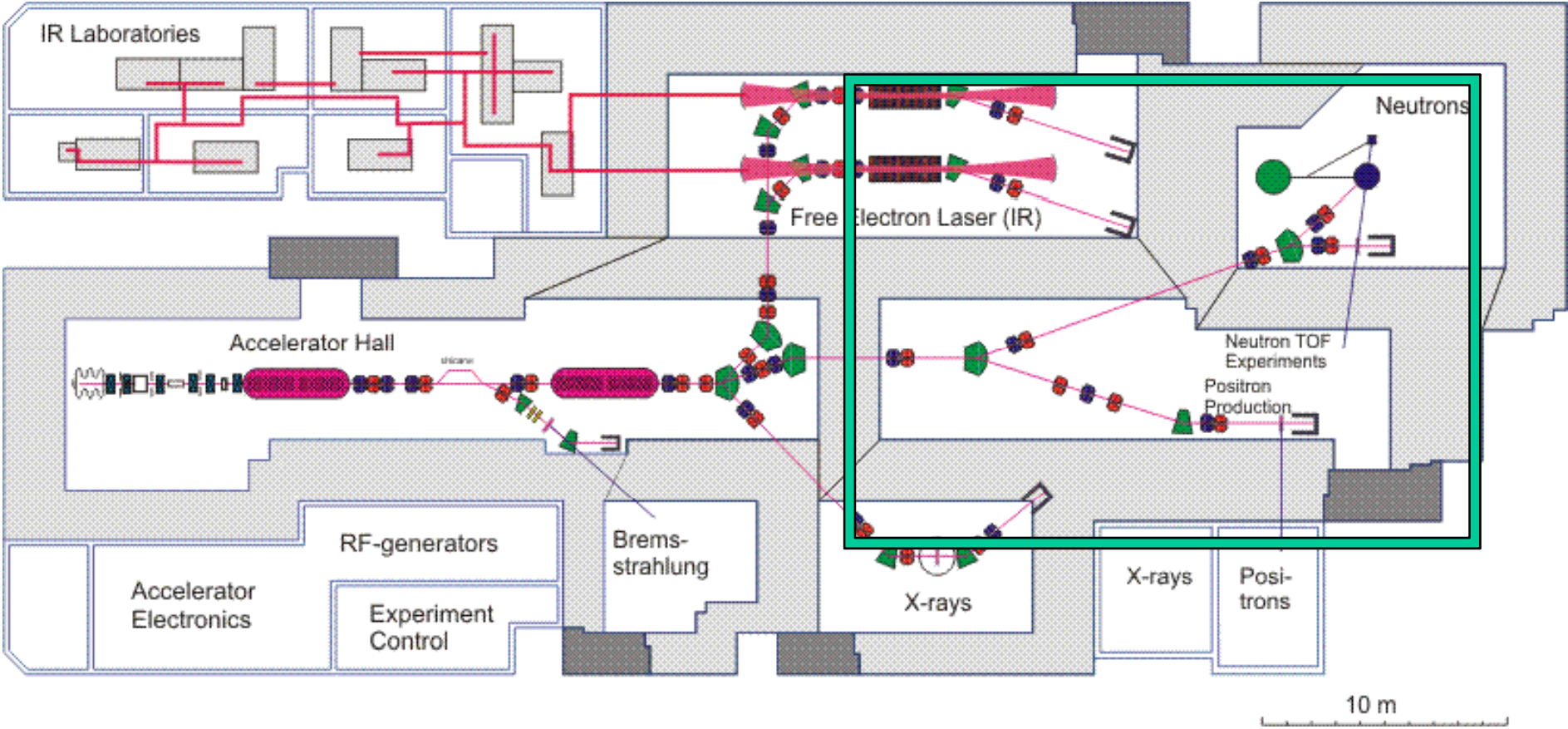

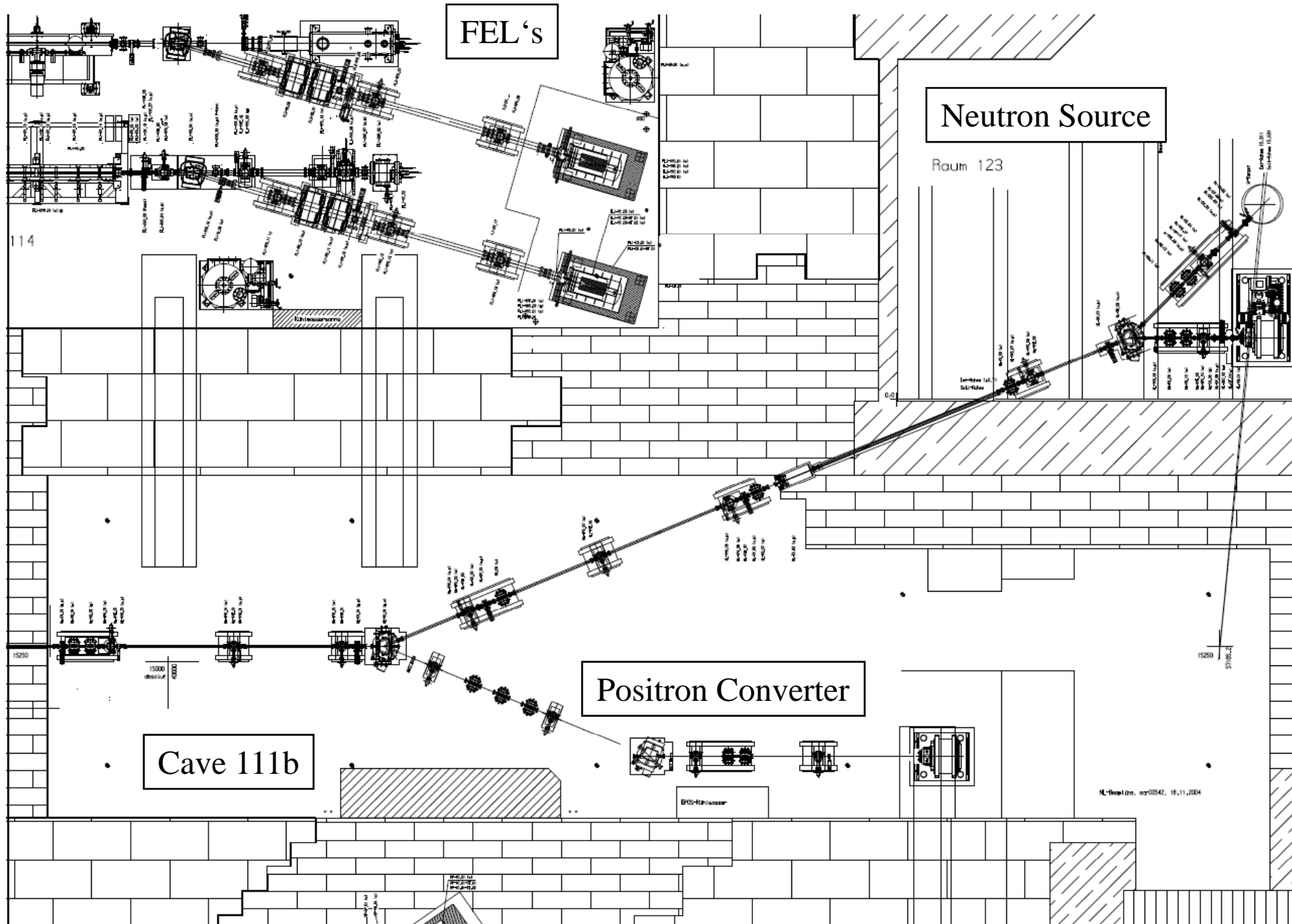



Cave 111b

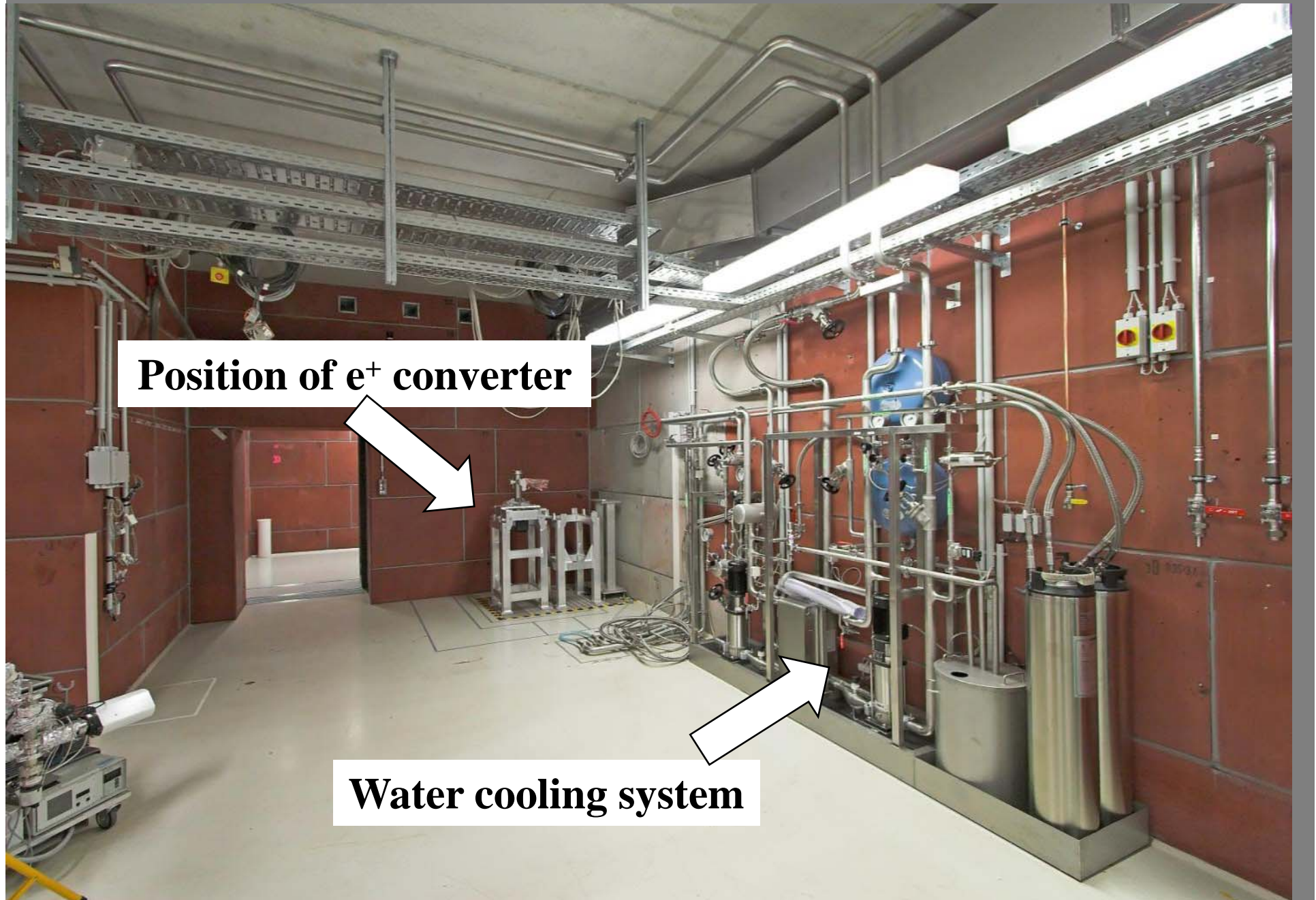

Position of e^+ converter

Water cooling system

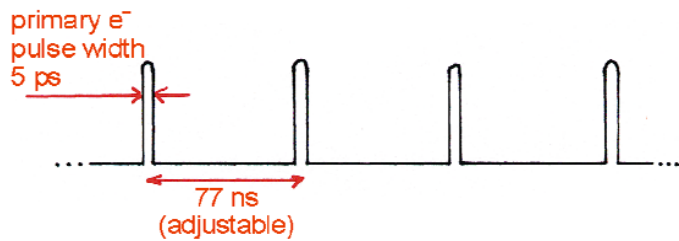
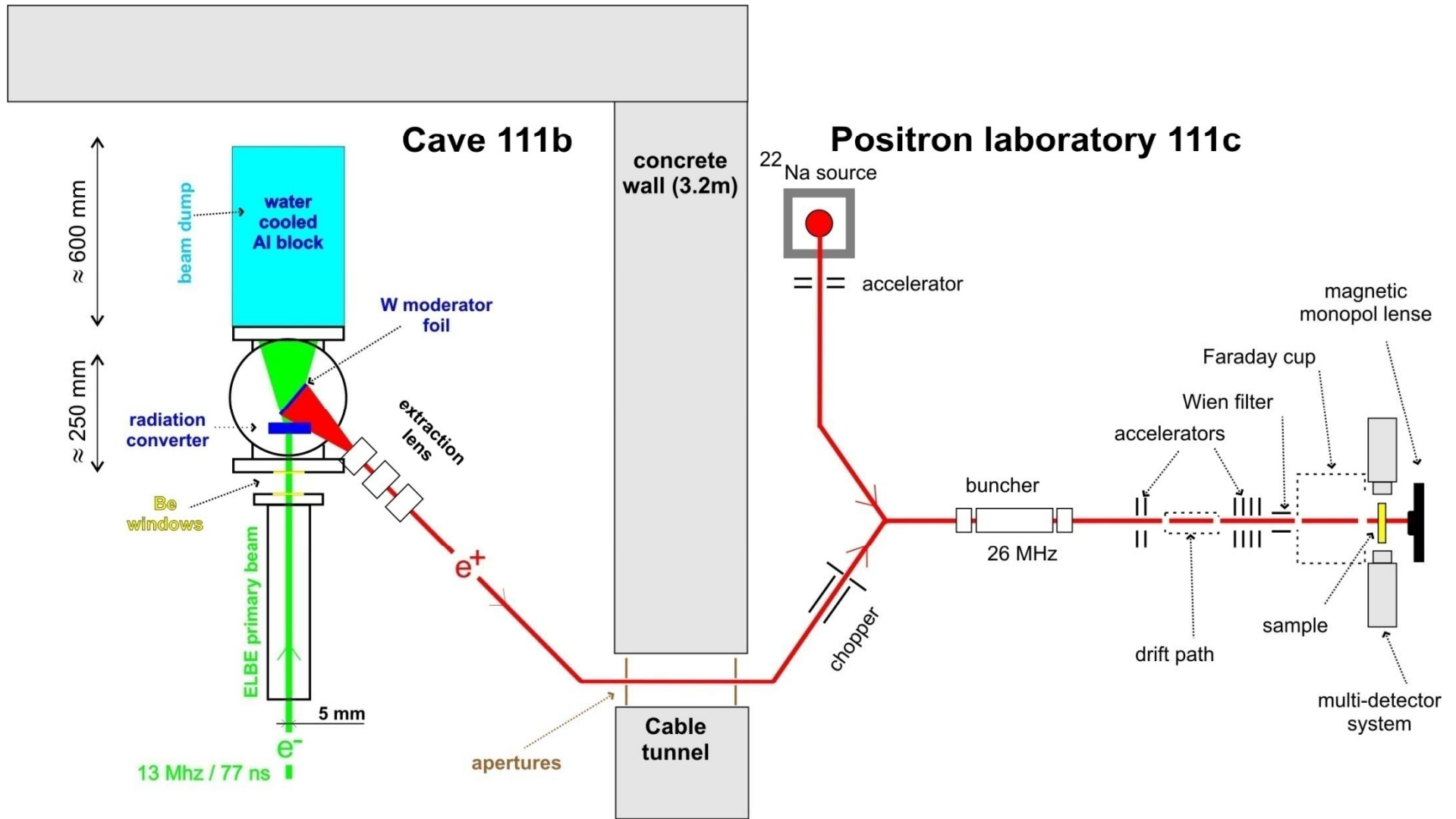

EPOS scheme



Directly water-cooled Electron-Positron Converter

- stack of 50 pieces W-foils 0,1 mm separated by 0,1 mm -> 13,5 l water at 1,5 bar
- foils cut by IR-laser in our workshop

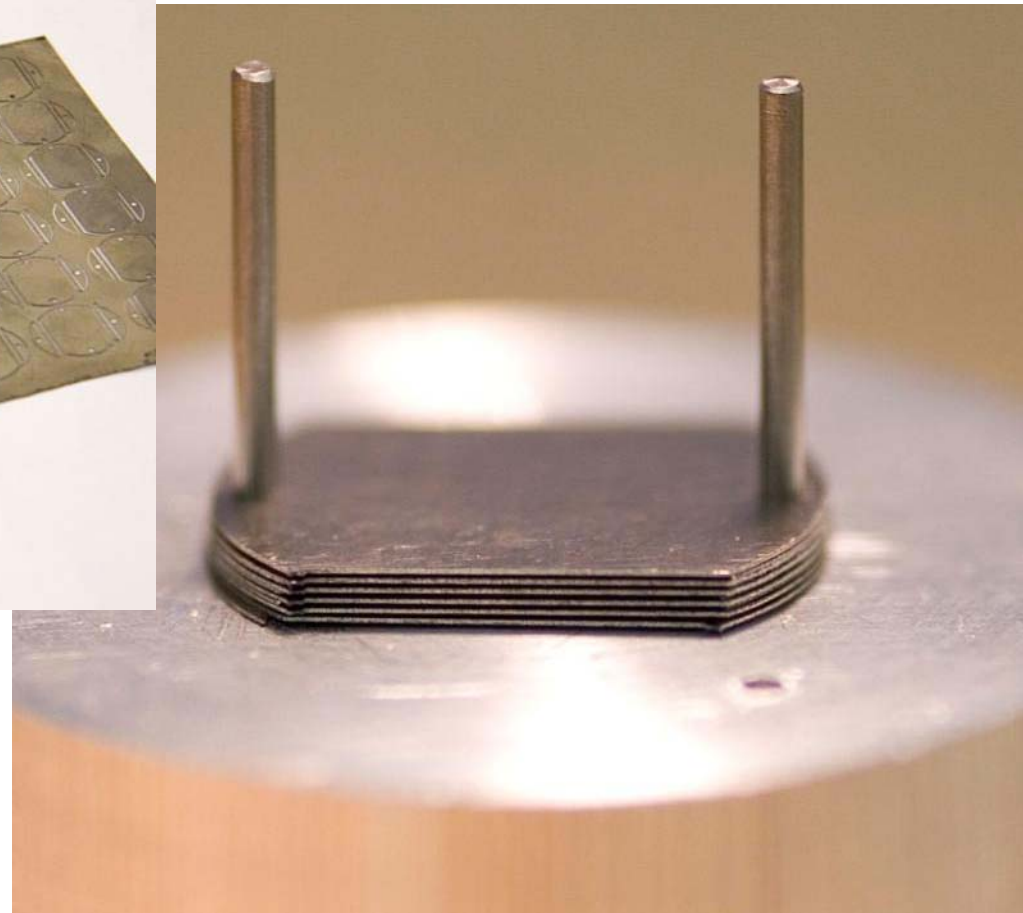
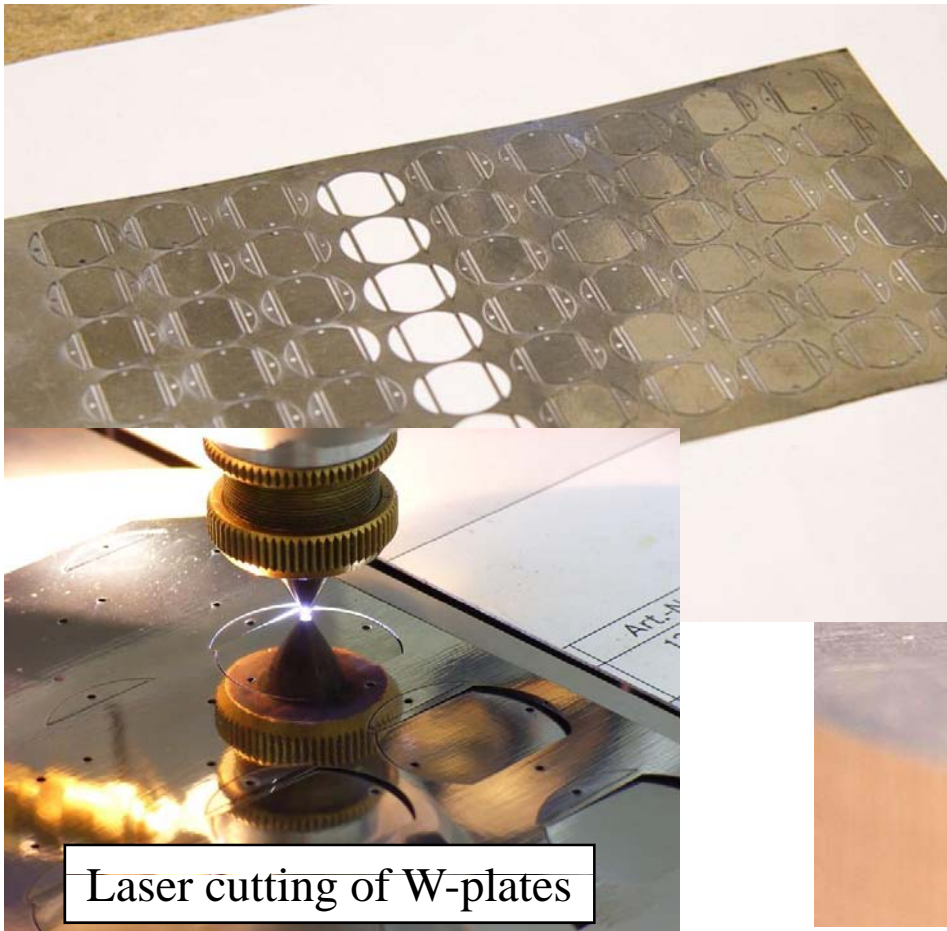

Directly water-cooled Electron-Positron Converter



Directly water-cooled Electron-Positron Converter

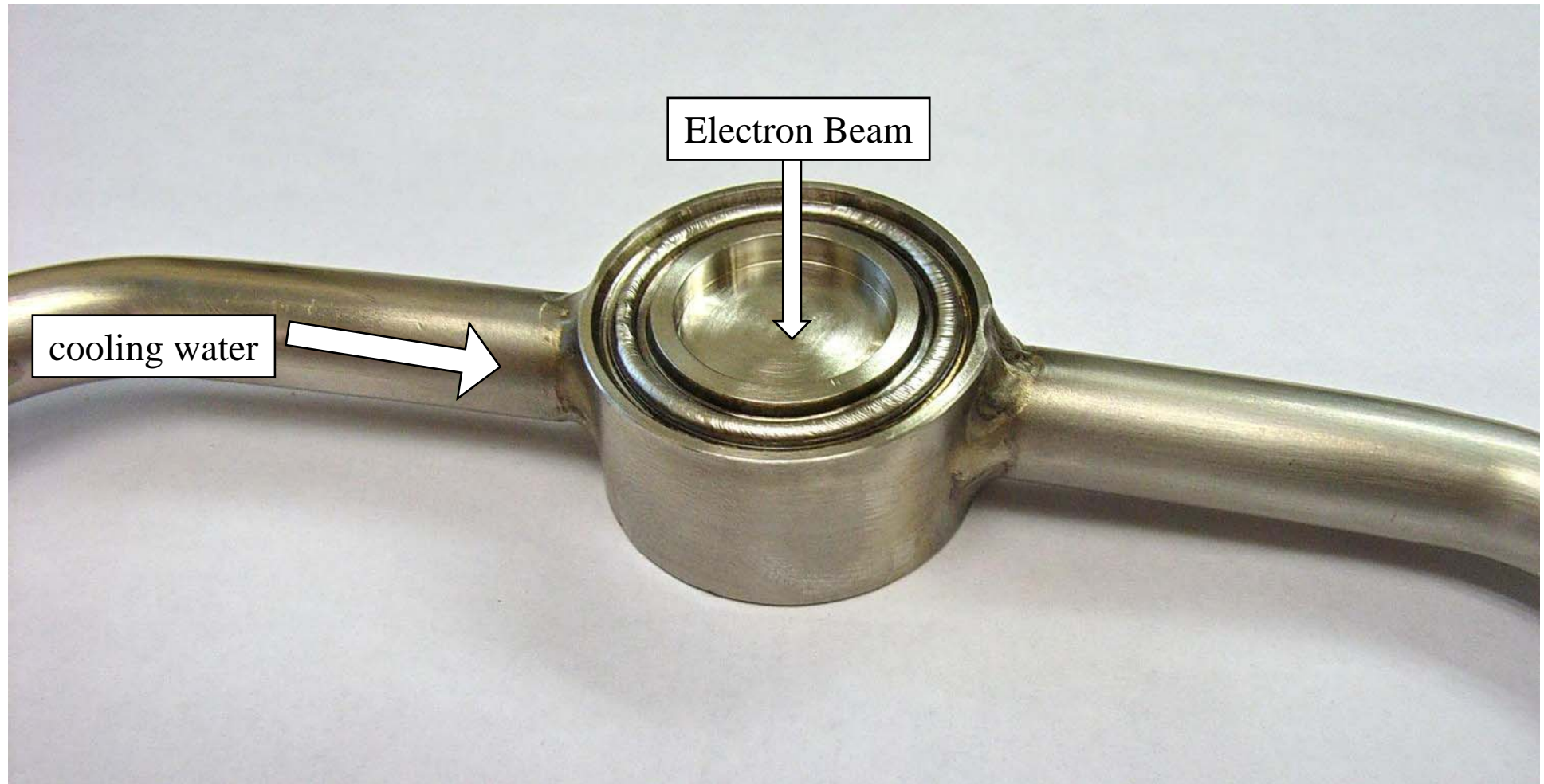

Simulation of Energy deposition

Al beam dump 21 kW
(made of 5N-purity)

W target
14 kW

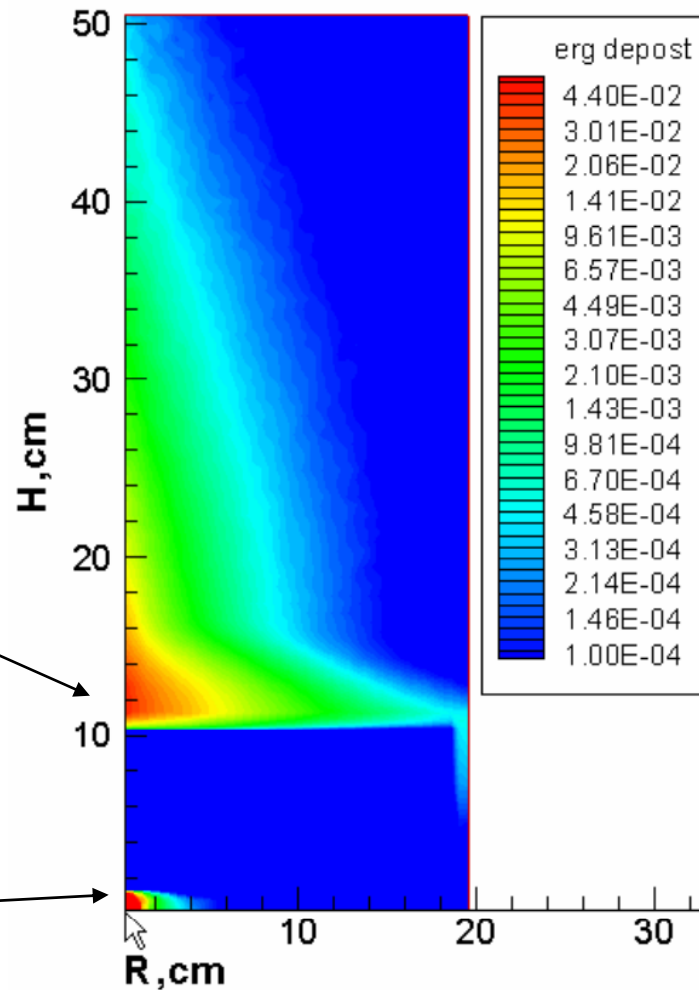

EPOS Density Energy Deposition (in MeV/cm³) for Distance = 10cm

↑ primary beam



Positron extraction electrodes

Cave 111b

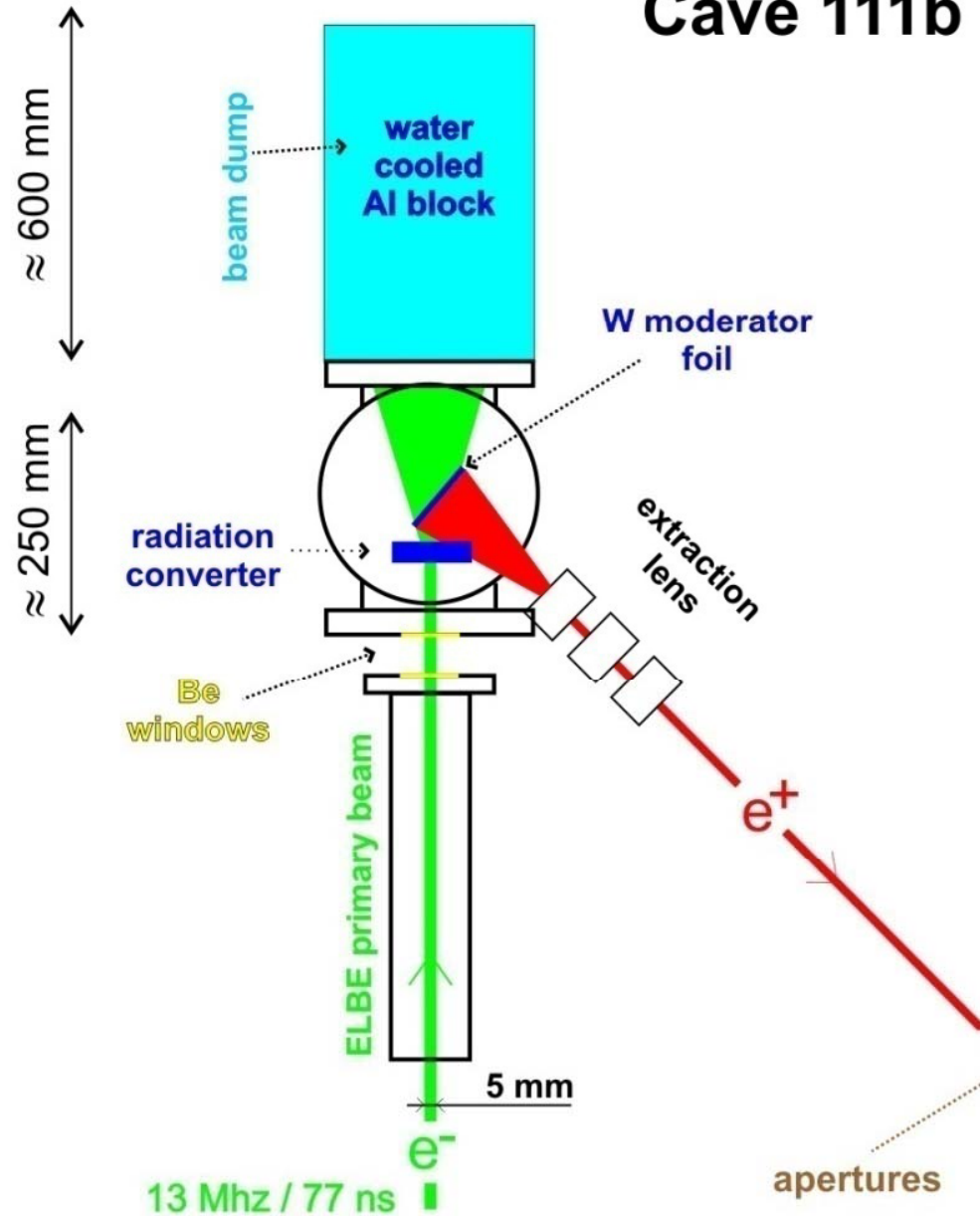

Simulation of positron extraction

- simulation done by EGUN
- area of 20 mm diameter at moderator is used and squeezed to about 2 mm

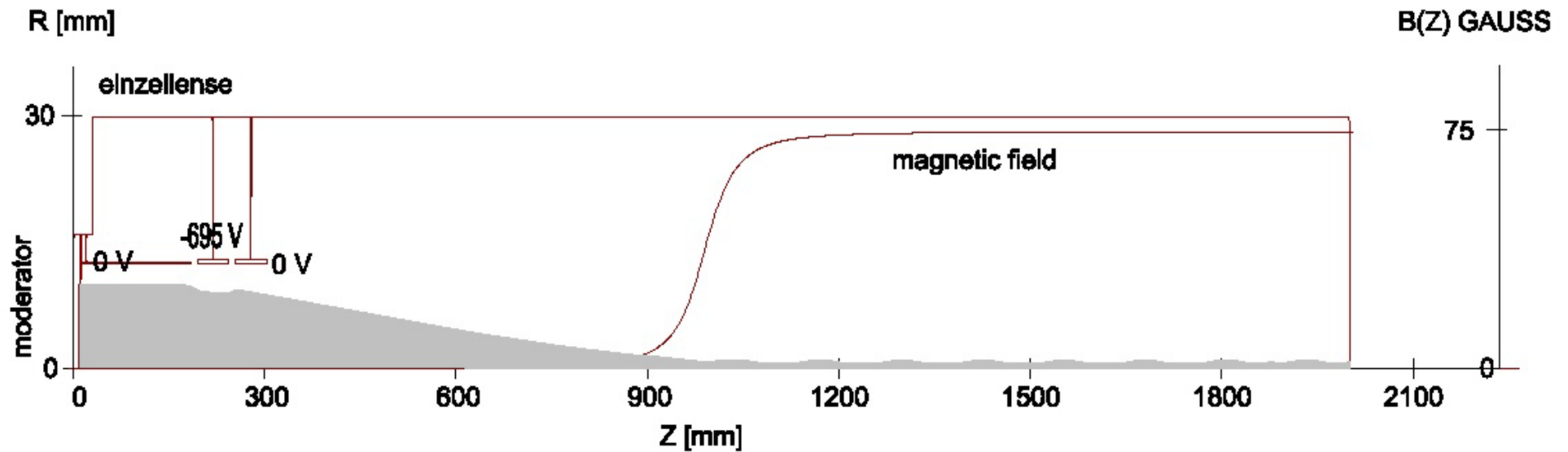

Positron extraction electrodes

- stainless steel mesh
- 90% opening
- in front of Einzel lens
- provides very homogenous 2 kV-field

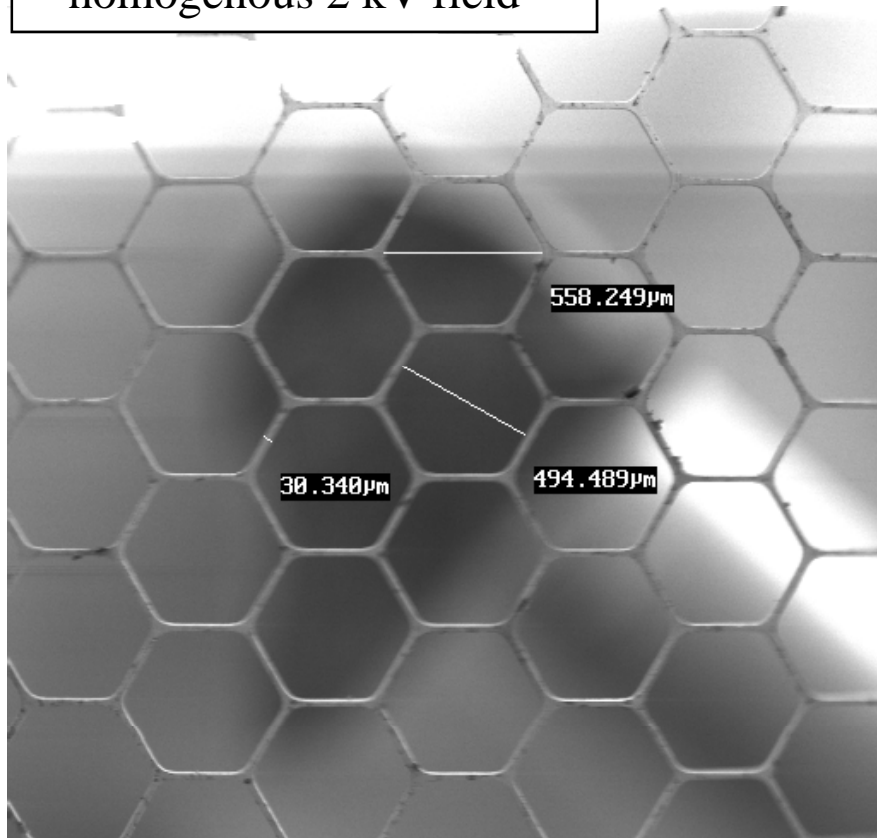

m.j005_se_53x_04.06.2007

1mm

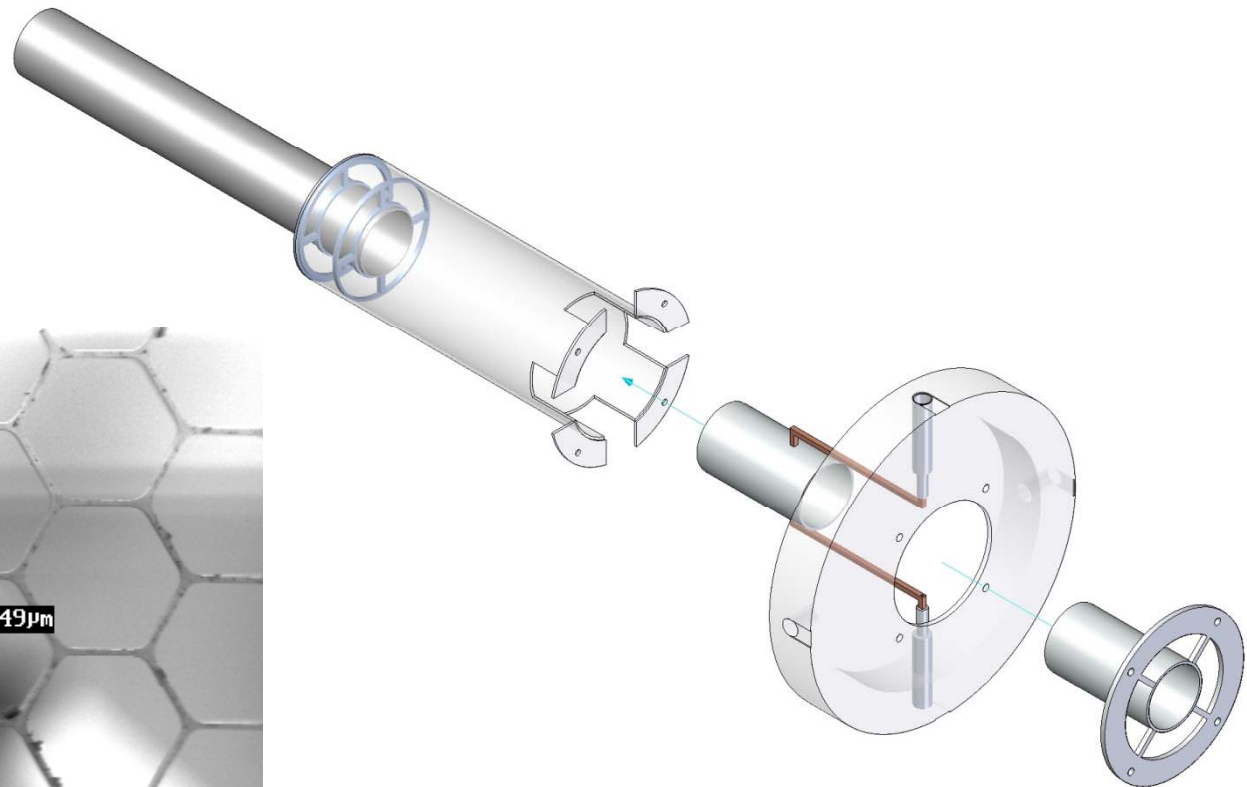

Einzel lens for extraction

Magnetic Beam Guidance System

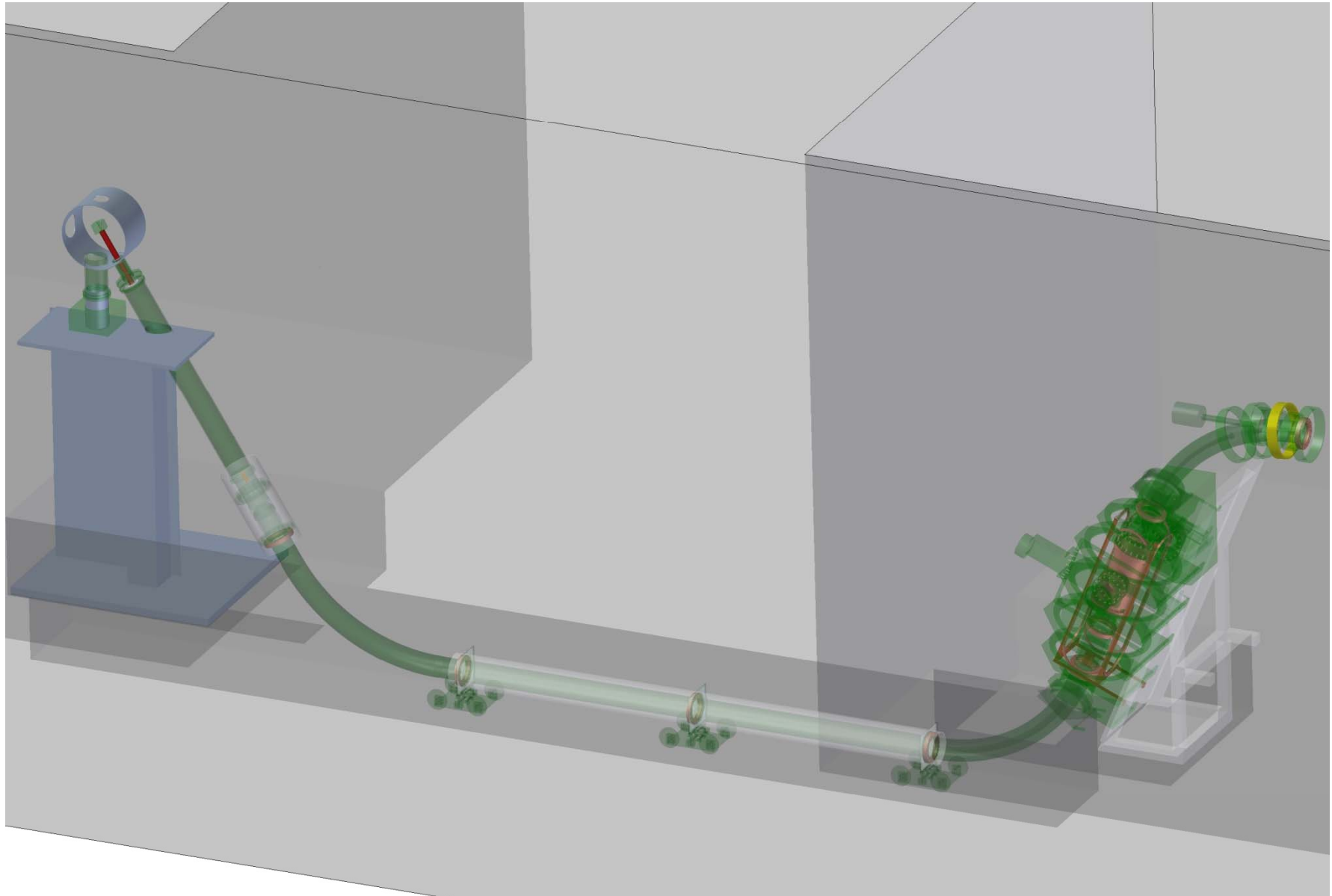

Magnetic Beam Guidance System

Magnetic field of 75 Gauss provides by long coils and Helmholtz coils

- 45 coils but only
- 5 different currents
- 5 Power supplies

- maximum change 6 G
- gradient < 0.11 G/mm

30 pairs of steering coils with different (computer-driven) current sources

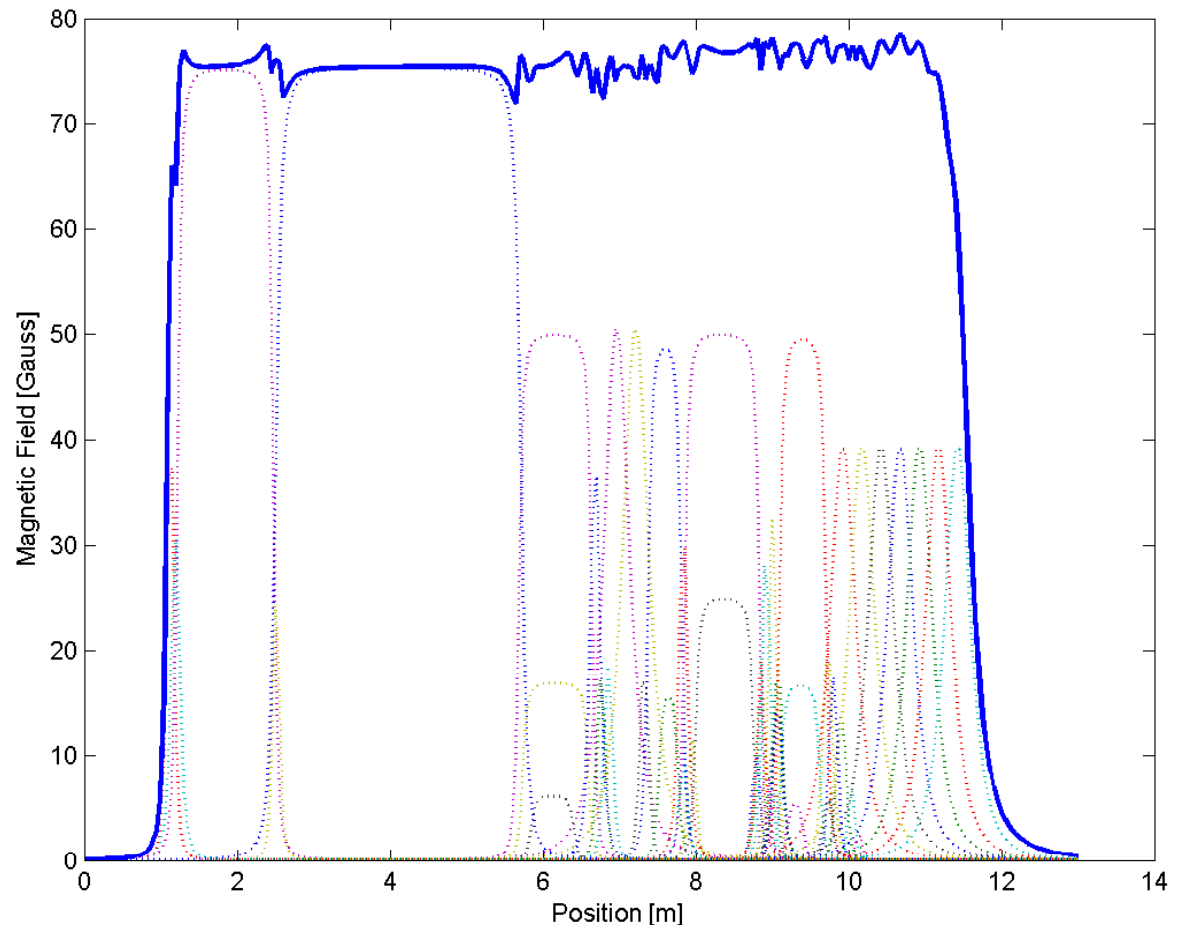

Chopper

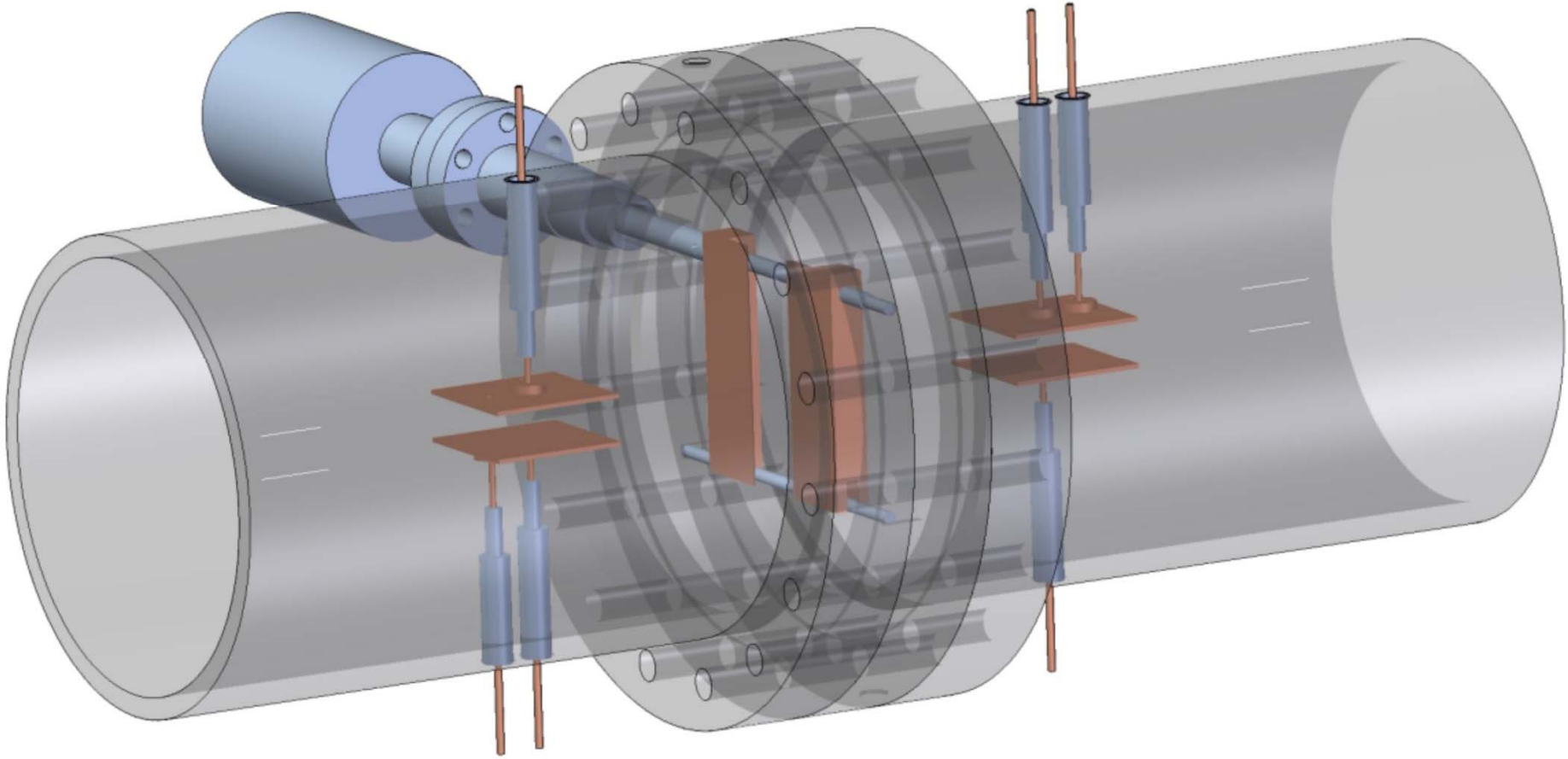

Deflection plates

adjustable chopper slit

adjustable aperture

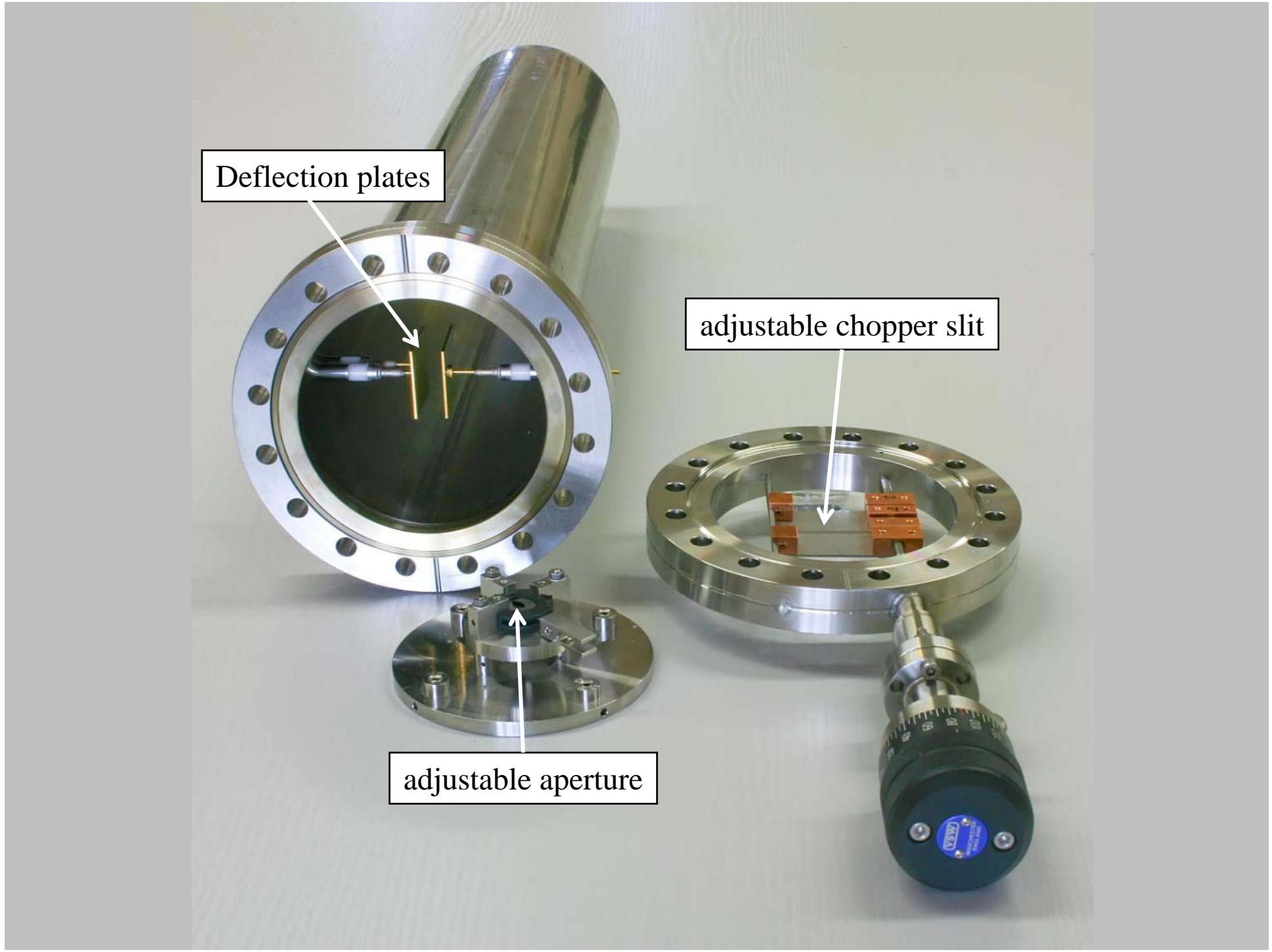

Double-slit harmonic Buncher

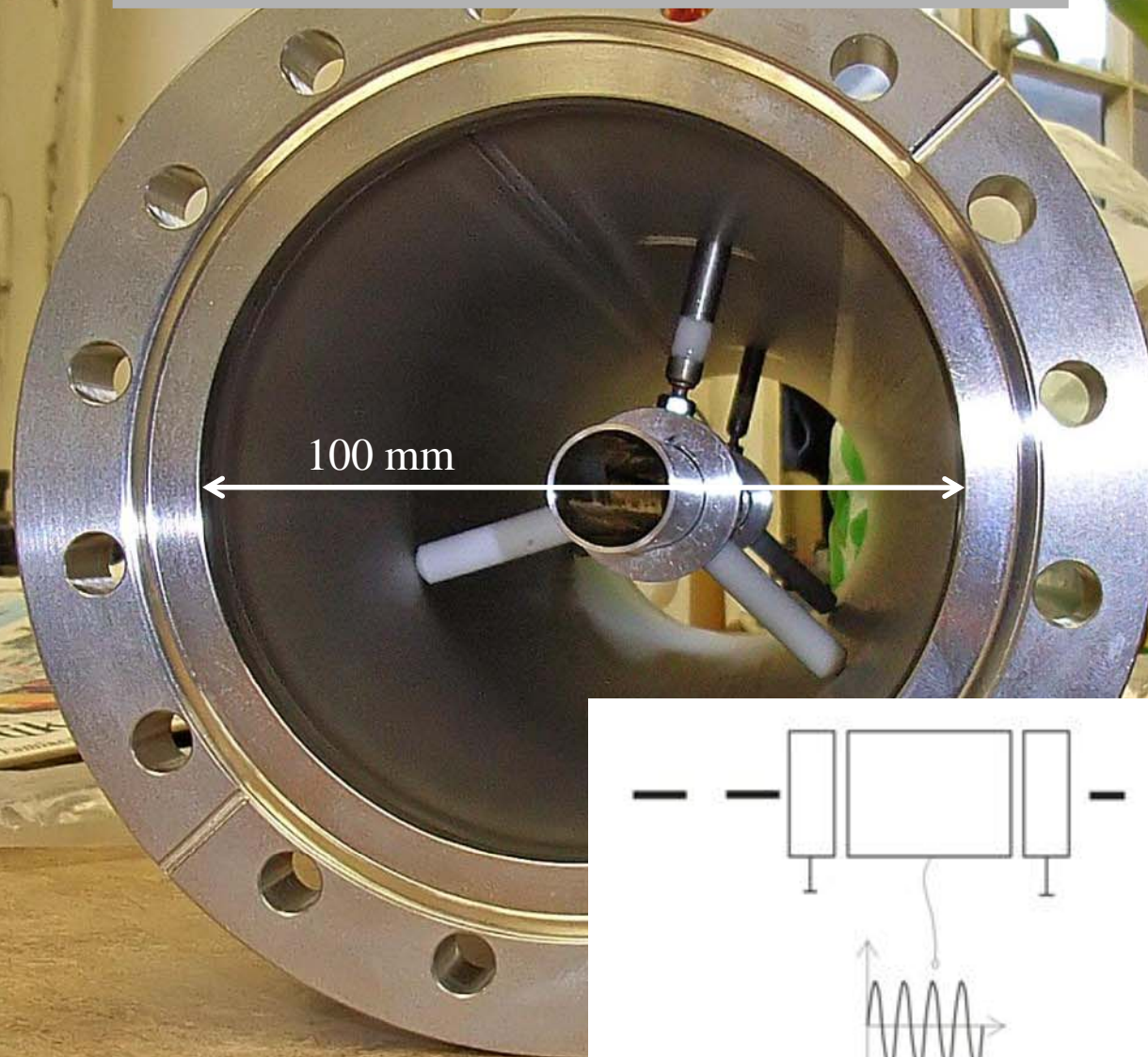

more Details of Chopper / Buncher system: Poster Bp-2 of Marco Jungmann

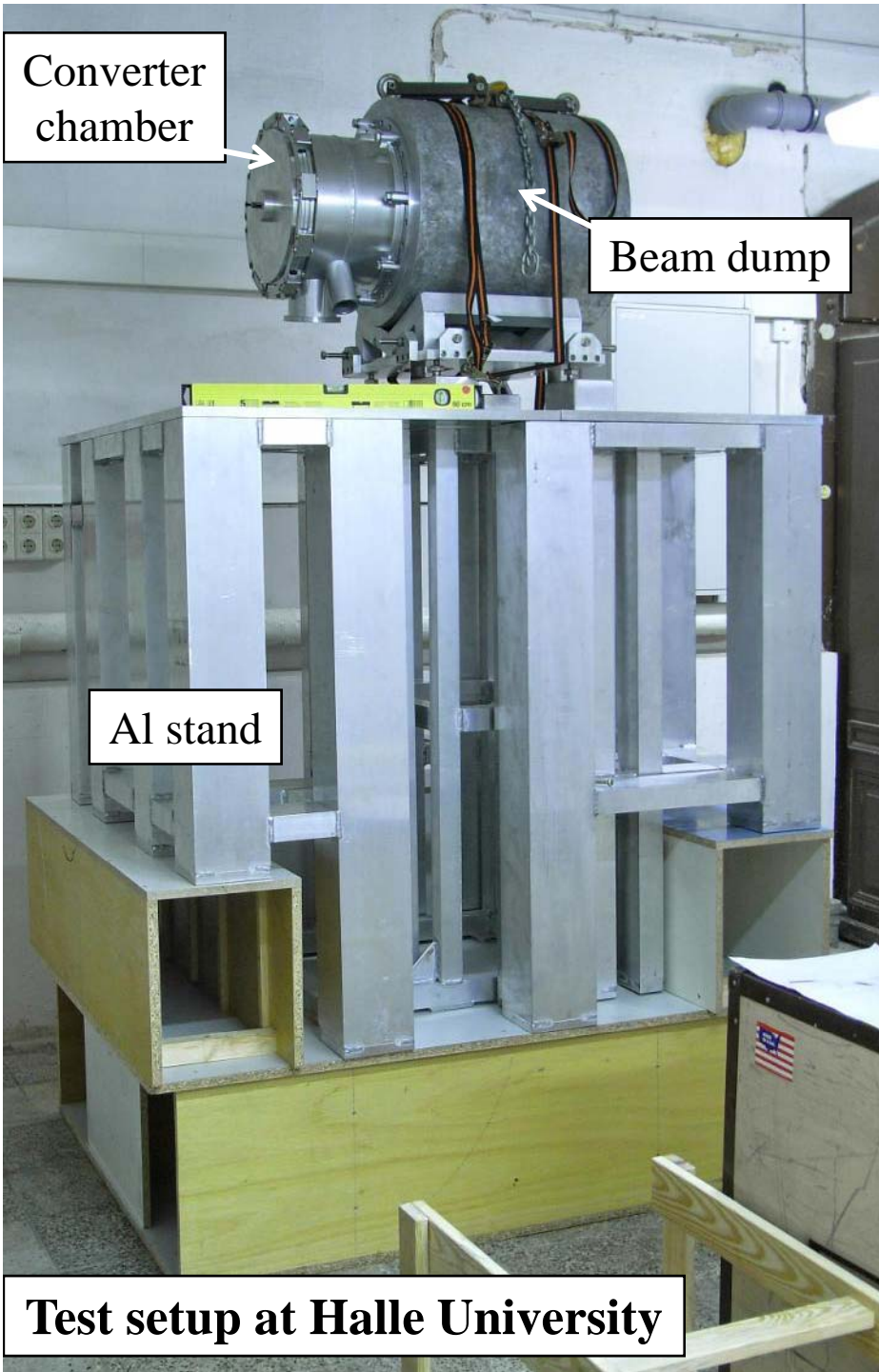

Radiation Protection

- Rather important dose rate $< 0.5 \mu\text{Sv/h}$ at any point outside of room 111b (also on ceiling)
- This corresponds to $1 \text{ mSv}/2000 \text{ h}$ which is the lowest level in radiation protection (normal environment)
- Does not require any measures of radiation protection



Top view

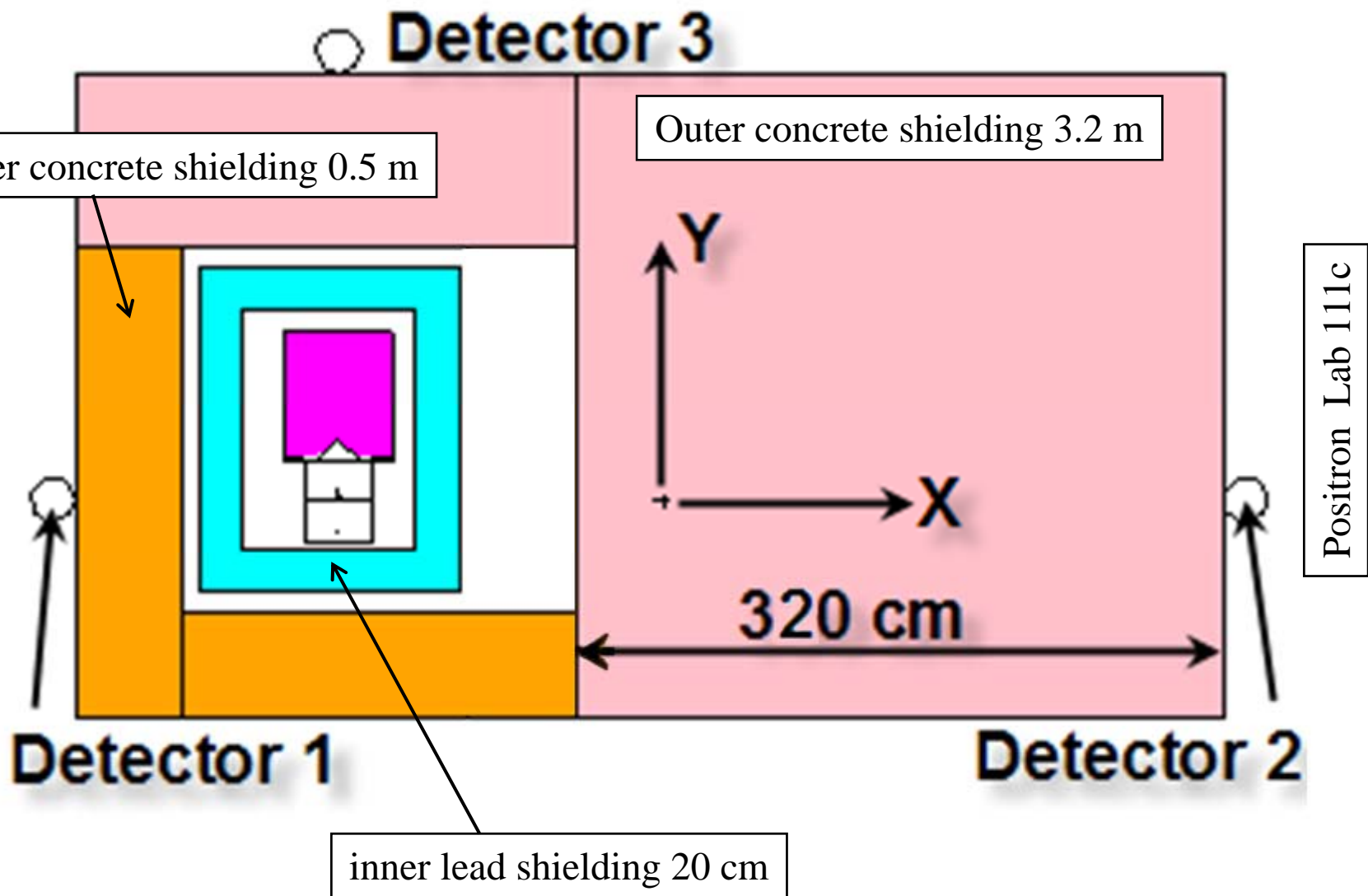

Simulation of expected γ and n dose

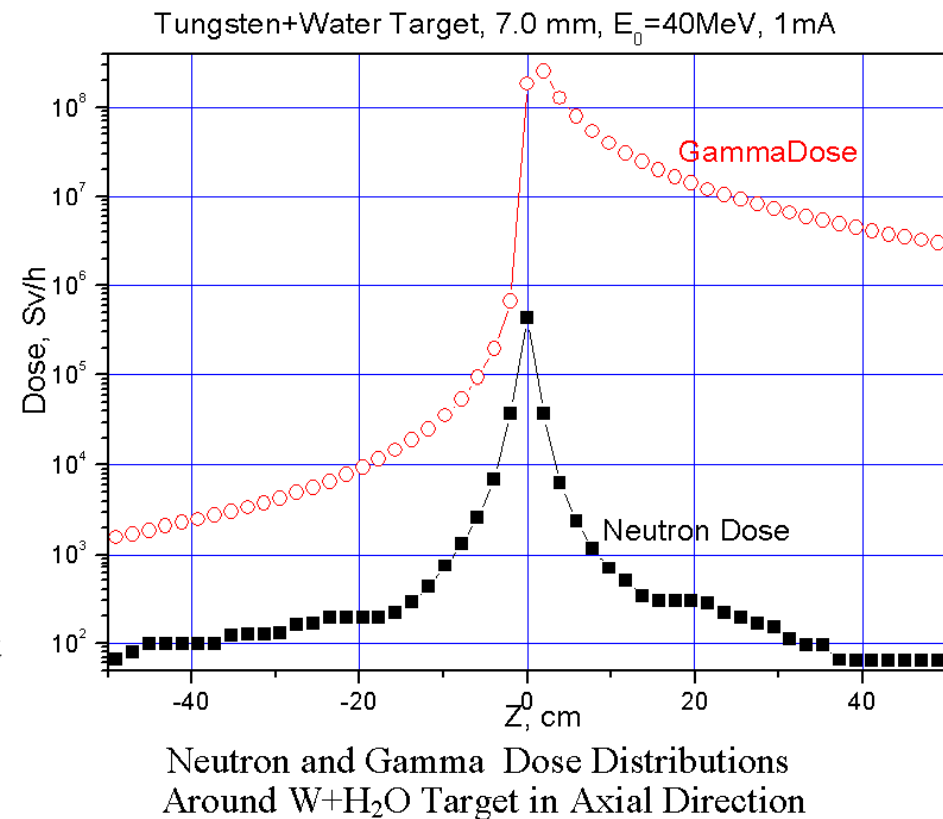
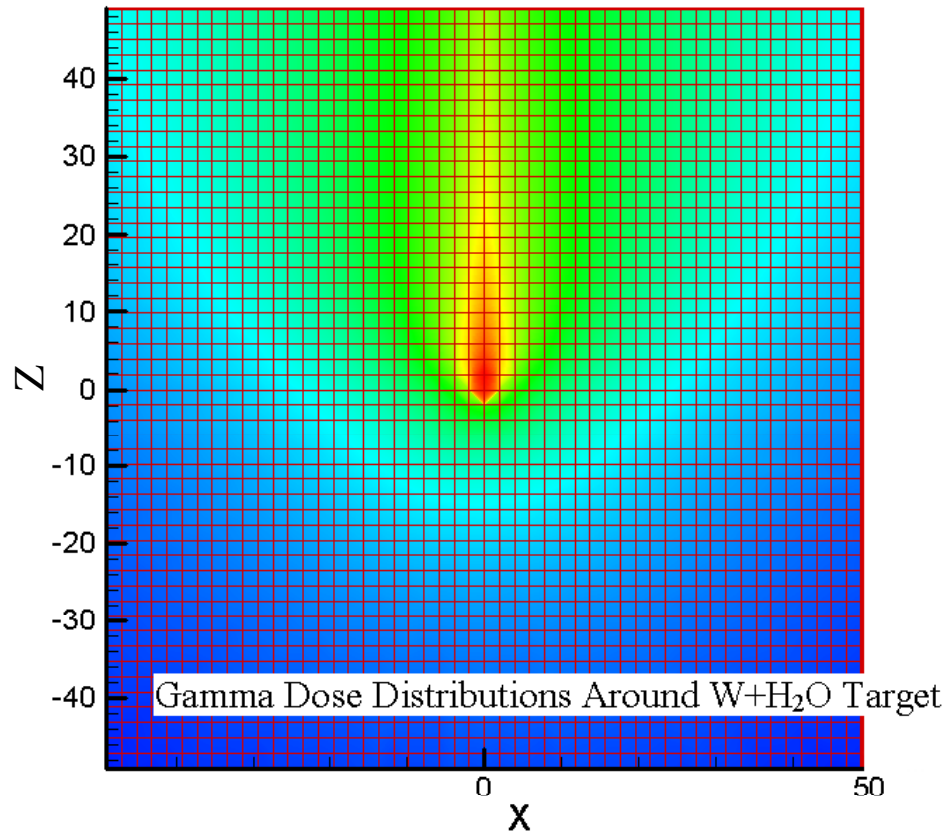

normal environment

$$D = 0.15 \mu\text{Sv/h}$$

$$D_{\gamma} > 0.25 \mu\text{Sv/h}$$

$$D_n > 0.6 \text{ mSv/h}$$

at ceiling (1.6 m concrete):

$$D_{\gamma} = 0.2 \mu\text{Sv/h}$$

$$D_n < 4 \times 10^{-6} \mu\text{Sv/h}$$

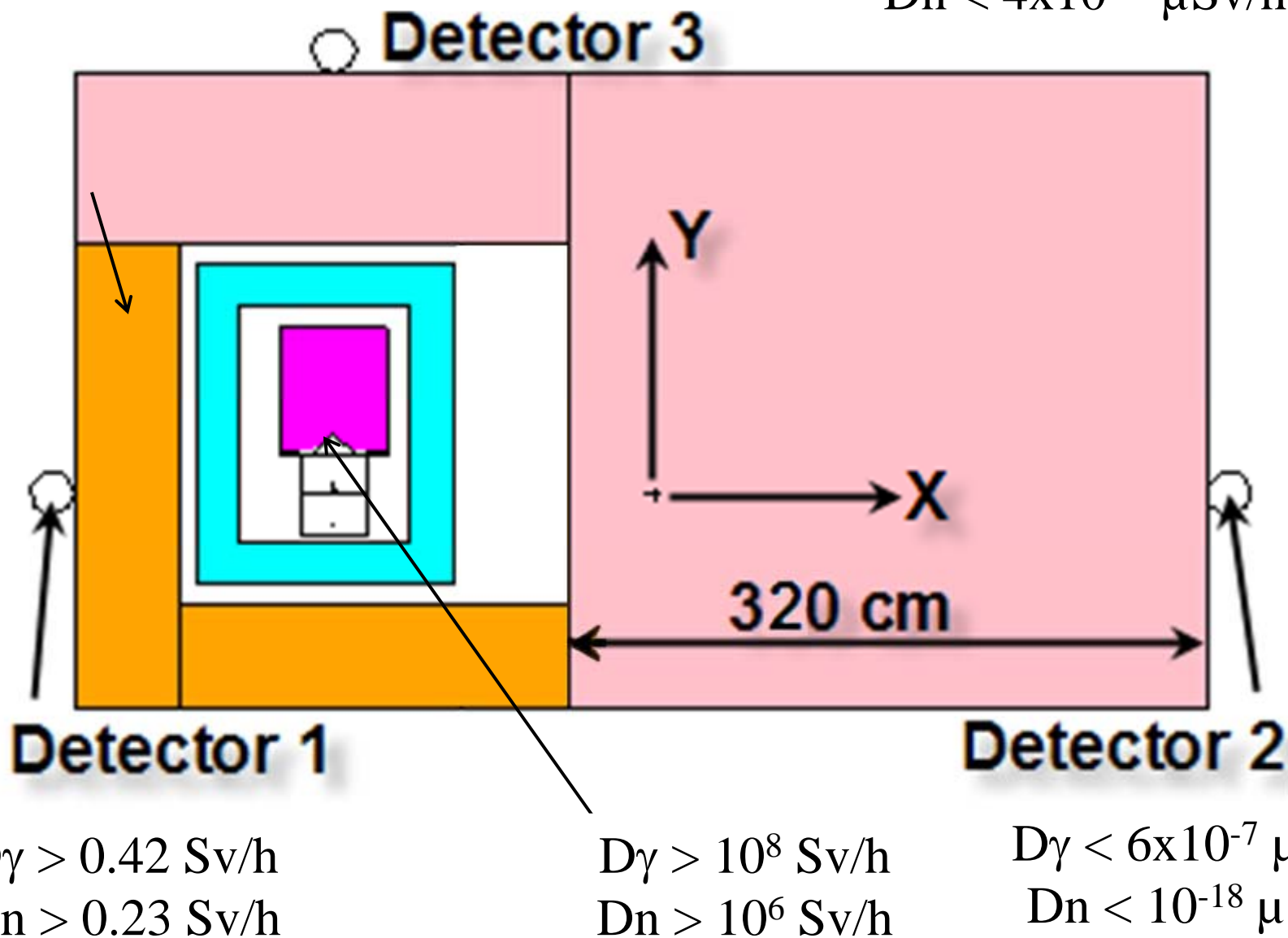

Detector system (see talk Do-4 Arnold Krille)

- **3 experiments:** lifetime spectroscopy (8 BaF₂ detectors); Doppler coincidence (2 Ge detectors), and AMOC (1 Ge and 1 BaF₂ detector)
- **complete digital detection system:**
 - lifetime: almost nothing to adjust; time scale exactly the same for all detectors; easy realization of coincidence
 - Doppler: better energy resolution and pile-up rejection expected
 - pulse-shape discrimination improves spectra quality

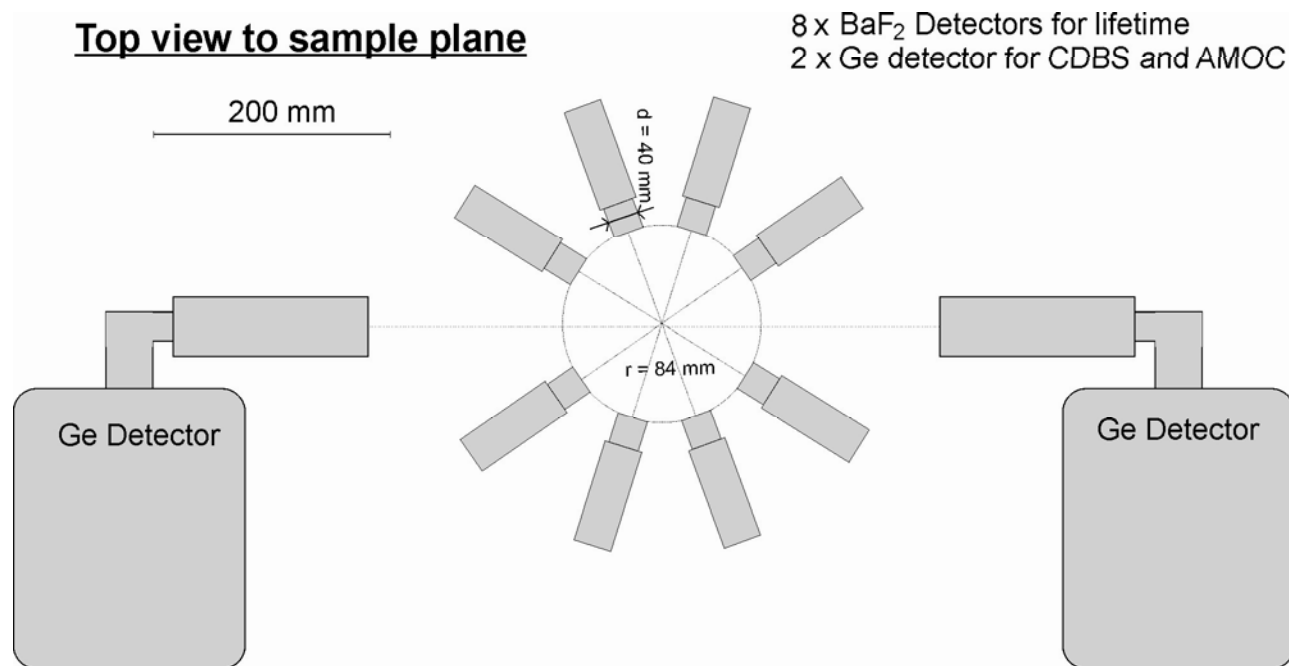

Conclusion

- System ready for installation at FZD in autumn 2007
- See the talk Do-4 of Arnold Krille tomorrow afternoon "Digital positron lifetime spectroscopy at EPOS"
- please visit our poster Bp-2 by Marco Jungmann "Construction and Timing System of the EPOS Beam System"
- This presentation can be found at <http://positron.physik.uni-halle.de>

